

entry-level
sound level meters



Instrument Handbook

CR:308 & CR:310
Entry-Level
Sound Level Meters

About this manual

The instructions in this user manual refer to the operation of Cirrus Research plc CR:308 and CR:310 entry-level sound level meters.

The instruments described in this manual are the CR:308 and CR:310.

This manual describes the recommended usage of the CR:308 and CR:310. Any warnings will be indicated by the following symbol:



The additional information required for testing in accordance with IEC 61672 is provided as a supplementary document, 'Optimus Sound Level Meters Technical Data Part B', which is available for download at: www.cirrusresearch.co.uk/library/user-manuals/

It is not possible to change the way that the instrument measures through software or firmware. Any legal metrology aspects of the instrument cannot be affected by any changes made in the instrument.

Copyright

Copyright © Cirrus Research plc 2010-2021

All rights reserved.

You may re-use this document/publication (not including the Cirrus Research plc logo and other product logos) free of charge in any format for research, private study or internal circulation within an organisation. You must re-use it accurately and not use it in a misleading context.

You must not modify text, images or illustrations in any way. The material must be acknowledged as Cirrus Research plc copyright, and you must give the title of the source document/publication.

Where any third-party copyright material is identified, you will need to obtain permission from the copyright holders concerned.

Trademarks

Cirrus Research plc, the Cirrus Research plc Logo, doseBadge, DOSEBADGE, Optimus, the NoiseTools Logo and the Noise-Hub Logo are either registered trademarks or trademarks of Cirrus Research plc in the United Kingdom and/or other countries. Microsoft and Windows are registered trademarks of Microsoft, Inc. All other trademarks acknowledged.

Updates

In the interests of continuous product improvement, Cirrus Research plc reserves the right to make changes to product specifications without notice.

To understand the latest updates that have been implemented into this product and to download the most current version of this user manual, visit our website at www.cirrusresearch.com

Revision 2 | August 2021

Contents

| | | |
|-----------|--|-----------|
| 1 | Introduction | 5 |
| 2 | First use | 6 |
| 3 | Instrument overview | 7 |
| 4 | Instrument displays..... | 9 |
| 4.1 | CR:308 & CR:310 main display | 9 |
| 4.2 | Calibration display | 9 |
| 4.3 | CR:308 alarm set display | 10 |
| 4.4 | CR:310 measurement display | 10 |
| 5 | Instrument keypads..... | 11 |
| 5.1 | CR:308 keypad | 11 |
| 5.2 | CR:310 keypad | 11 |
| 6 | Instrument operation | 12 |
| 6.1 | Selecting the frequency and time weighting..... | 12 |
| 6.2 | Maximum, minimum and LCpk values | 12 |
| 6.3 | Setting the level alarm (CR:308 only) | 12 |
| 6.4 | Performing and printing a measurement (CR:310 only)..... | 13 |
| 7 | Instrument calibration..... | 15 |
| 8 | Specifications and technical information..... | 16 |
| 8.1 | Instrument specifications | 16 |
| 8.2 | Reference information for periodic testing | 16 |
| 9 | Options and accessories..... | 19 |
| 10 | Serial connection..... | 20 |
| 11 | Declaration of Conformity..... | 21 |
| 12 | Product guarantee and extended warranty..... | 22 |
| 13 | Cirrus Research contact details | 23 |

1 Introduction

Welcome to your new CR:308/CR:310 entry-level sound level meter.

The CR:308 and CR:310 are general-purpose digital sound level meters designed to IEC 61672 Class 2. The instrument has 'F' (fast) and 'S' (slow) time response and 'A' and 'C' frequency weightings. Additional features include max and min hold for the measurement duration, LCpk, and limit alarm, which you can configure to indicate if your set threshold has been exceeded.

Except for the alarm indication function, the CR:310 includes all the features of the CR:308. In addition, it can display the Leq value and print results directly from the meter to a portable printer.

2 First use

Before using your meter for the first time, please check the contents of your instrument's case, which should include the following:

- Sound level meter and Class 2 microphone
- Windshield
- 2 x AA batteries

Optional accessories

- Class 2 acoustic calibrator

You may have other accessories, depending on your package.



Before starting a measurement, remove the black microphone protective cap (if fitted) and where necessary, place the windshield carefully over the end of the microphone capsule.

3 Instrument overview





4 Instrument displays

4.1 CR:308 & CR:310 main display

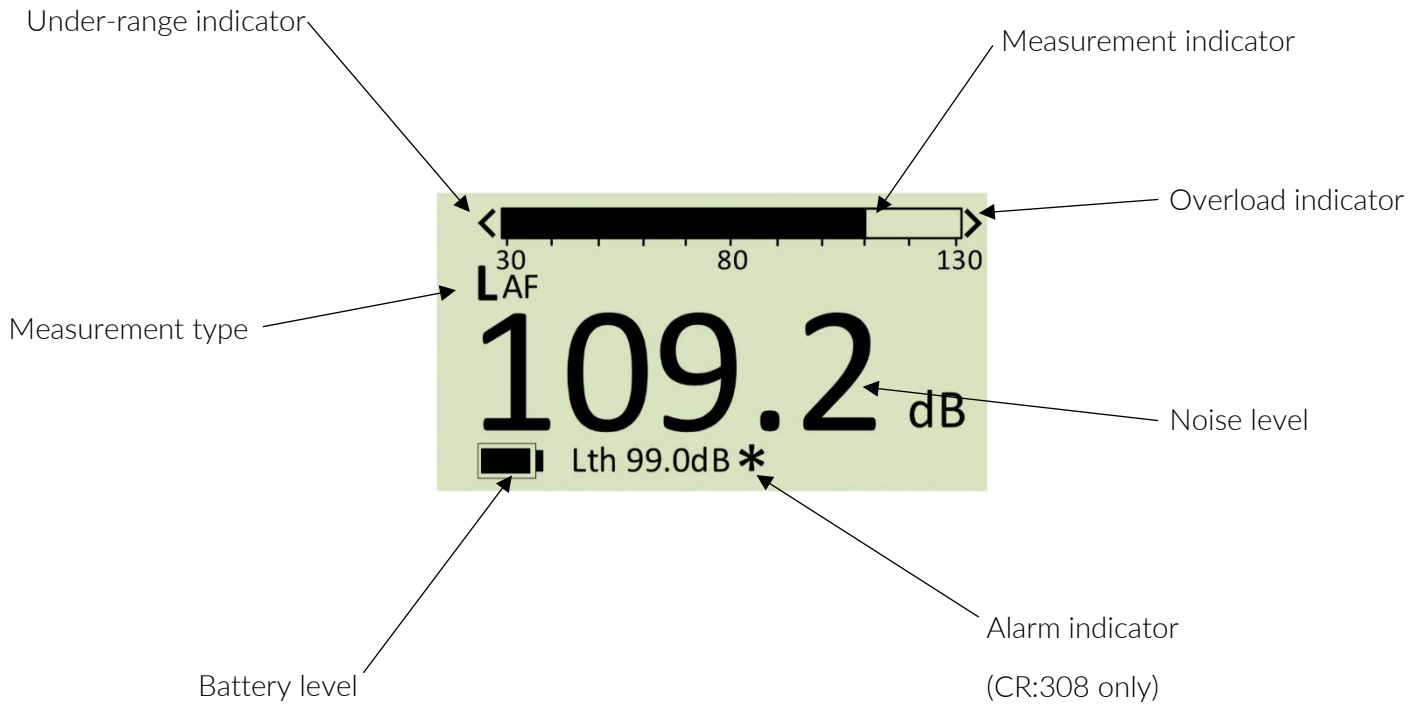

4.2 Calibration display

Press the CAL button.

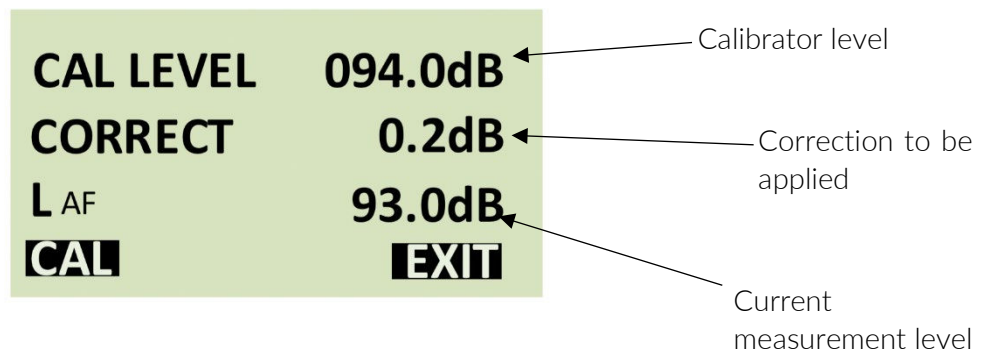

4.3 CR:308 alarm set display

Press  .

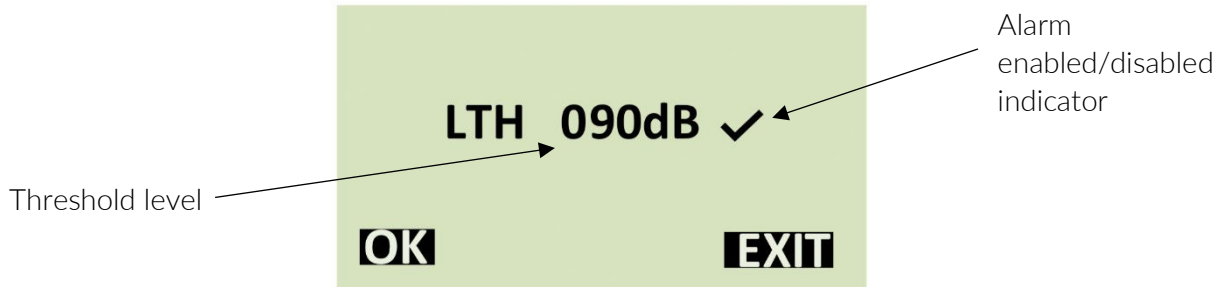

4.4 CR:310 measurement display

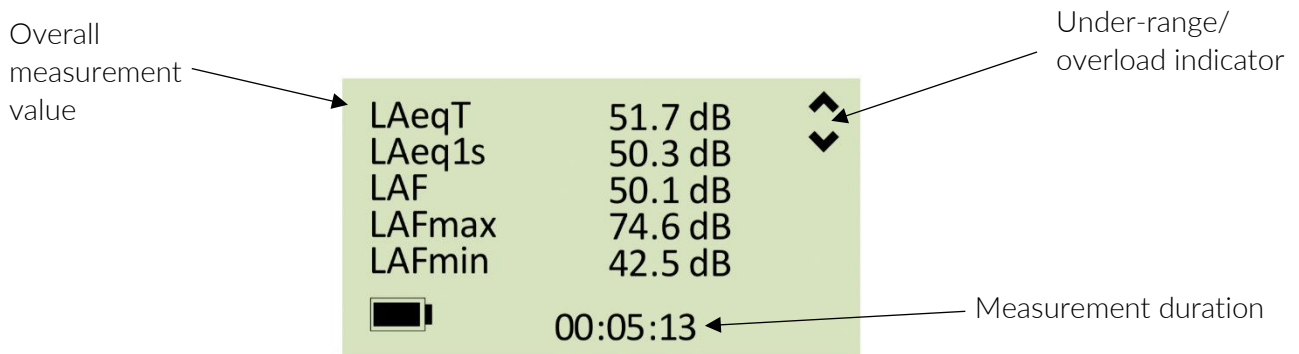

5 Instrument keypads

5.1 CR:308 keypad

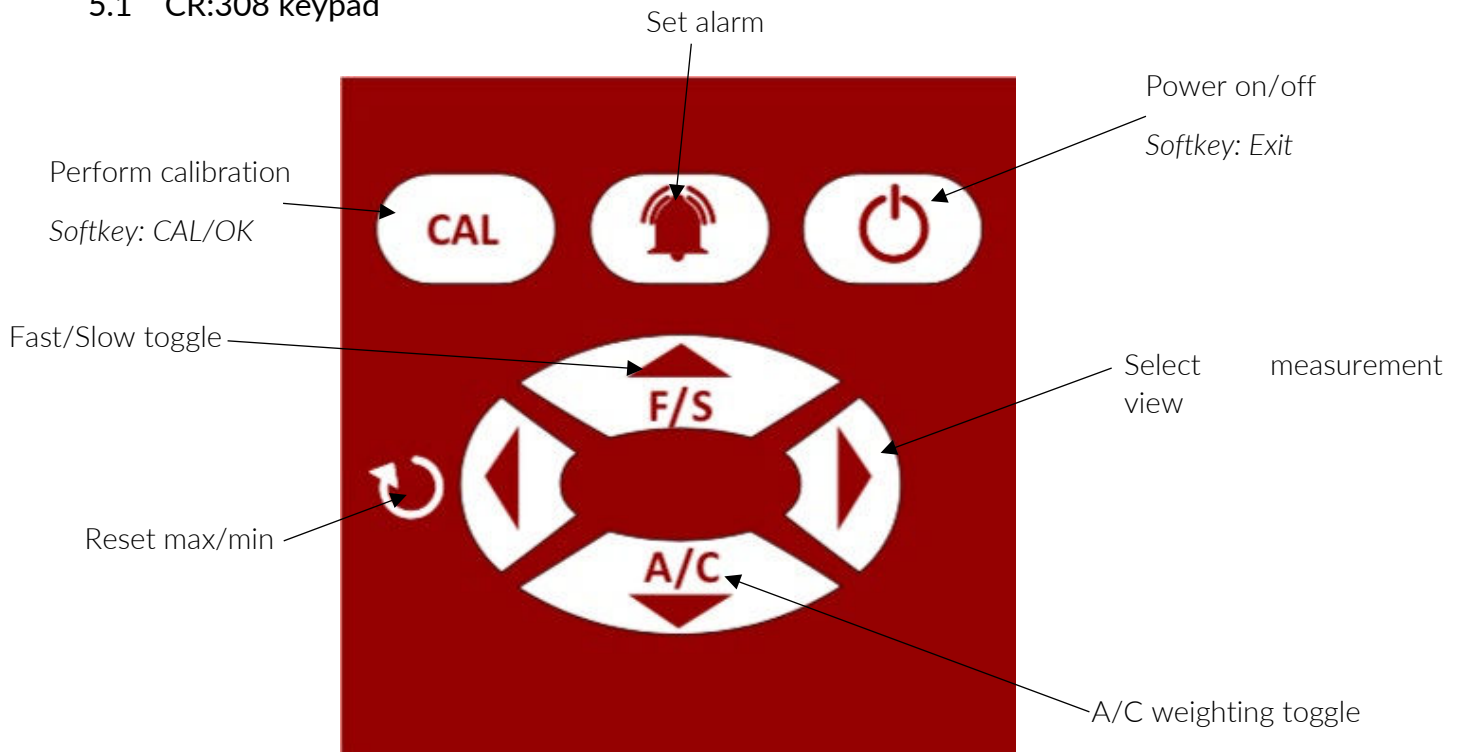

5.2 CR:310 keypad

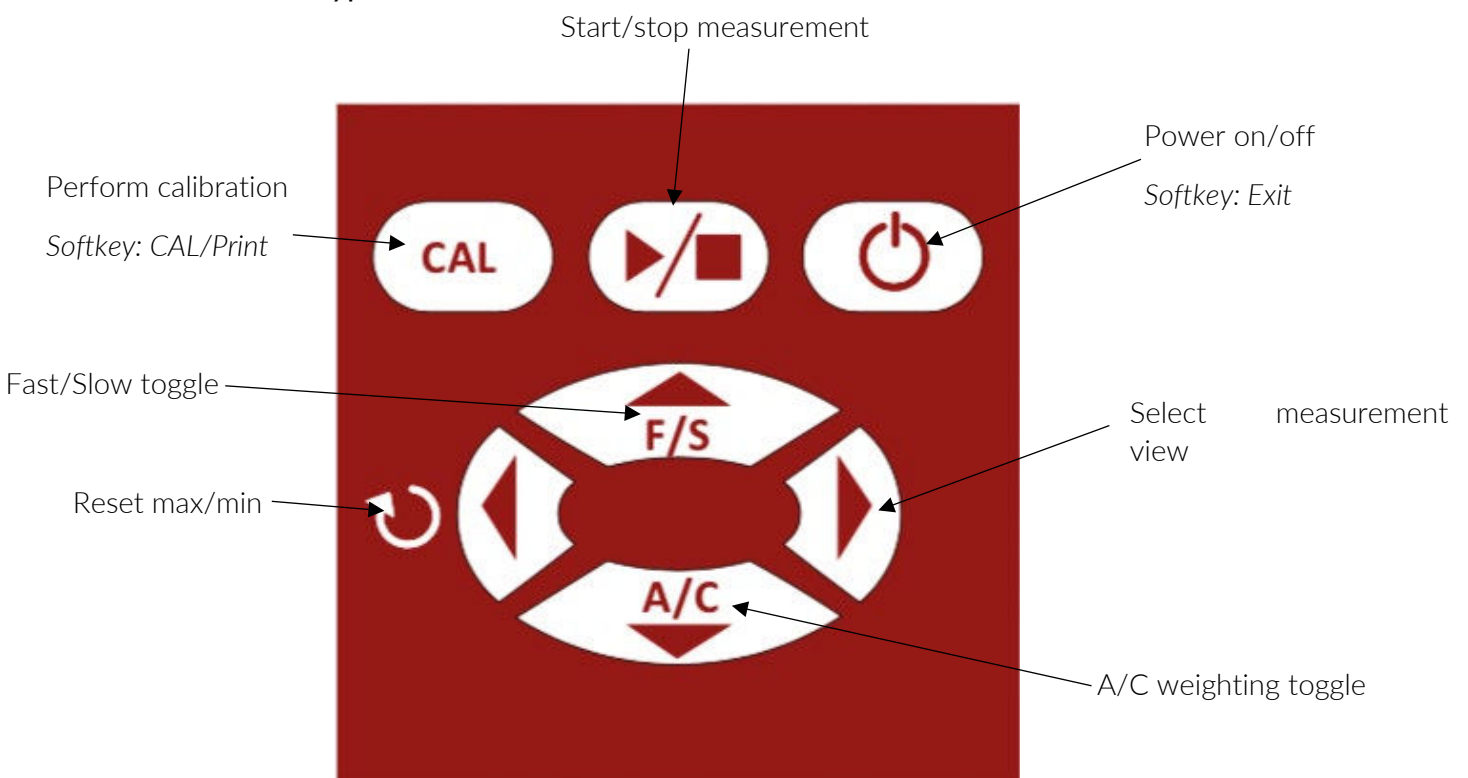

6 Instrument operation

Fit new batteries by sliding the battery cover open and inserting two AA batteries in the correct orientation.

Switch on and allow the instrument to settle for 60 seconds before calibrating.

Before starting a measurement, calibrate the instrument as per the guidance in Section 7 of this user manual.

6.1 Selecting the frequency and time weighting

Select the measurement frequency and time weighting required:

To toggle between A and C weighting, press 

To toggle between fast and slow weighting, press 

The measurement type is displayed in the main window:

LAF – A frequency weighting | fast time weighting

LCF – C frequency weighting | fast time weighting

LAS – A frequency weighting | slow time weighting

LCS – C frequency weighting | slow time weighting

To toggle the measurement values, press . This will toggle through the following measurement values if the meter is set to LAF:

LAF > LAFMax > LAFMin > LCpk > LAF

Integrating averaging measurements Lxeq1s and Lxeq8h are available on the CR:310 instrument.

6.2 Maximum, minimum and LCpk values

Maximum, minimum and LCpk values are shown for the duration of time since the meter was switched on or since the reset button was last pressed.

These values can be reset by pressing 

6.3 Setting the level alarm (CR:308 only)

The level alarm function can be used to trigger an alert if the noise level exceeds a predetermined value, which is set by you.

To set the alarm level, press  to enter the alarm setup display.

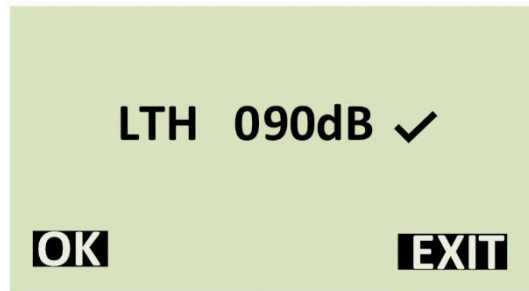

Set the desired level and enabled the alarm by using the arrow buttons. A tick denotes that the alarm is active; a cross denotes that the alarm is disabled. When set, press  to confirm.

NB: the alarm level should not be set to less than 129dB.

With the alarm enabled, the main display will indicate that the level has been exceeded by showing an asterisk (*) next to the sound level reading. The triggered threshold value can be reset by pressing .

NV: this will also reset the maximum, minimum and LCpk measurement values.

6.4 Performing and printing a measurement (CR:310 only)

Press  to start or stop a measurement.

While a measurement is running, the latest values will be displayed on the screen, with the measurement duration shown at the bottom. Alternative measurement parameters can be viewed by pressing the up/down arrow buttons.

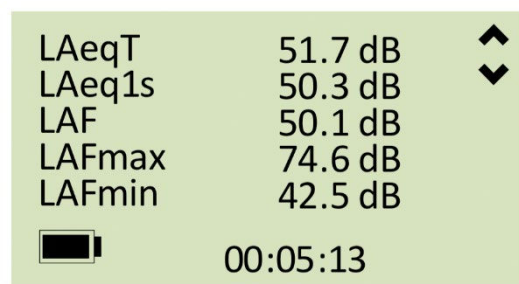

Overload and under-range are denoted by the ^ and v indicators in the top right corner of the screen.

After stopping a measurement, the overall measurement values are displayed. Press the up/down arrows to scroll through the overall measurement values.

| | |
|---------------|-----------------|
| Tm | 00:05:27 |
| LAeq1 | 51.8dB |
| LAeq8h | 32.3dB |
| PRINT | EXIT |

If a printer is attached, the results can be printed by pressing  (Print).

The measurement view can be cancelled by pressing  (Exit).

7 Instrument calibration

Before each measurement, it is important to calibrate your instrument with an acoustic calibrator, such as the Cirrus Research CR:514 1kHz 94dB calibrator.

To start the process of calibration, ensure the microphone is fitted correctly and place the acoustic calibrator over the microphone.

Press  to enter the calibration menu.

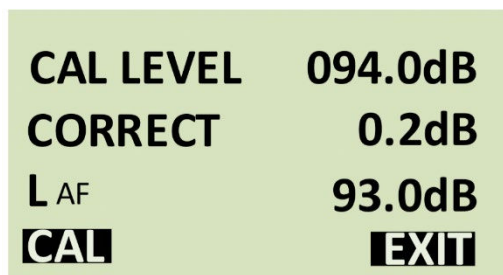

| | |
|------------------|----------------|
| CAL LEVEL | 094.0dB |
| CORRECT | 0.2dB |
| L AF | 93.0dB |
| CAL | EXIT |

Use the arrow keys to set the CAL LEVEL to the acoustic calibration level (94.0dB for the CR:514 calibrator).

Use the arrow keys to set the CORRECT value to 0.2dB, which will make the adjustment for the gap between the calibrator and the microphone (pressure field of the acoustic calibration and the free field of the instrument and microphone (HY:205 microphone).

This will result in the meter reading 93.8dB when a 94dB calibrator is used.

Switch on the acoustic calibrator and insert the microphone capsule into the cavity on the calibrator. Take care to not force the microphone, as this could cause damage to either the instrument or the calibrator.

Press  to automatically calibrate the meter.

Press  to exit from the calibration display and return to the main display.

8 Specifications and technical information

8.1 Instrument specifications

| | |
|------------------------------|---|
| Applicable standards | IEC 61672-1: 2013 Class 2 |
| Measurement range | 30dB(A) – 130dB(A) 40dB(C) – 130dB(C) |
| Frequency weighting | A and C |
| Time weighting | Fast (F) and Slow (S) |
| Display functions | Normal, Maximum, Minimum, CPeak |
| Measurement functions | LAF, LAS, LCF, LCS, LCPeak |
| Noise floor | <25dB(A) and 35dB(C) |
| Display flags | Alarm limit, overload and under-range |
| Auto calibration range | ±4.5dB |
| Reference point | 94dB (1kHz), 92.9dB (8kHz) |
| Settling time | 60s |
| Display | Backlit 128x64 LCD |
| Resolution | 0.1dB |
| Electrical input | 5V power-in via mini-USB |
| Power | 2 x AA/LR6 1.5V batteries or 5V DC via mini-USB input |
| Battery life | 24 hours with alkaline batteries |
| Microphone | ½" pre-polarised electret condenser type HY:205 |
| Operating temperature | 0°C to +40°C |
| Operating humidity | 25% – 90% |
| Atmospheric pressure | 65kPa – 108kPa |
| Storage temperature | -20°C to +60°C |
| Dimensions | 215mm x 68mm x 32mm |
| Weight (including batteries) | 220g |
| Electrical outputs | AC (tip 3.5mm jack) and DC (middle 3.5mm jack) |
| DC output | Voltage 15mV/dB, range 450mV – 1950mV |
| AC output | RMS 2V |

8.2 Reference information for periodic testing

| | |
|--|--|
| Reference level (1kHz) | 94dB |
| Reference level (8kHz) | 92.9dB(A) |
| Linear range 8kHz | 30 – 130dB |
| Linear range 4kHz | 30 – 130dB |
| Linear range 1kHz | 30 – 130dB |
| LCPeak maximum (500Hz, 1kHz, 8kHz) | 133dB |
| Self-generated noise floor | A-weighting = 25dB C-weighting = 35dB |
| Self-generated noise floor (with mic fitted) | A-weighting = 25dB C-weighting = 35dB |
| Dummy microphone capacitance | 18pf |
| Recommended dummy microphone | KP:66 |

8.2.1 Multifrequency acoustic calibrator correction data (set to pressure and test on A-weighting)

| Frequency | Correction |
|-----------|------------|
| 125Hz | 0.0 |
| 1kHz | 0.2 |
| 8kHz | 2.6 |

8.2.2 Free field correction for HY205 microphone

| Frequency (kHz) | Free field correction (dB) | Frequency (kHz) | Free field correction (dB) |
|-----------------|----------------------------|-----------------|----------------------------|
| 1 | 0.1 | 6.3 | 1.7 |
| 1.25 | 0.1 | 8 | 2.6 |
| 1.6 | 0.2 | 10 | 4.4 |
| 2 | 0.3 | 12.5 | 5.3 |
| 2.5 | 0.5 | 16 | 6.5 |
| 3.15 | 0.7 | 18 | 7.1 |
| 4 | 1.0 | 20 | 7.8 |
| 5 | 1.4 | --- | --- |

8.2.3 Case reflection and windshield attenuation data

| Frequency (kHz) | Case correction | Windshield correction | Uncertainty |
|-----------------|-----------------|-----------------------|-------------|
| 63 | 0 | 0 | 0.27 |
| 125 | 0 | 0 | 0.27 |
| 250 | 0.13 | 0.05 | 0.27 |
| 500 | 0.18 | 0.08 | 0.27 |
| 1000 | 0.09 | 0.1 | 0.27 |
| 2000 | -0.16 | 0.26 | 0.27 |
| 4000 | 0.01 | 0.53 | 0.32 |
| 8000 | -0.10 | 0.26 | 0.30 |
| 16000 | -0.17 | -0.58 | 0.29 |

Add the above data to your measurement to correct.

8.2.4 Directionality plots and case reflection points

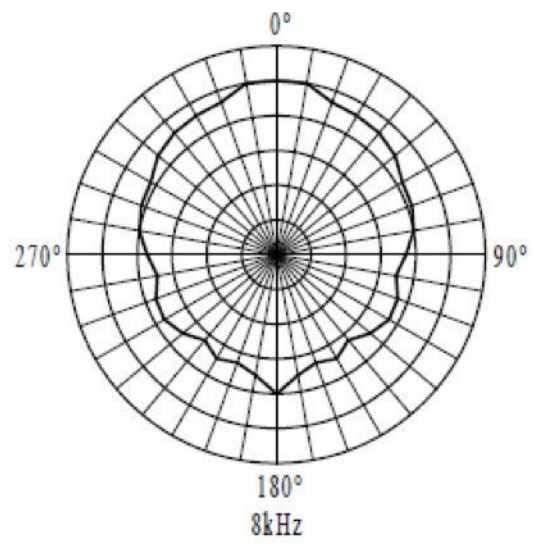
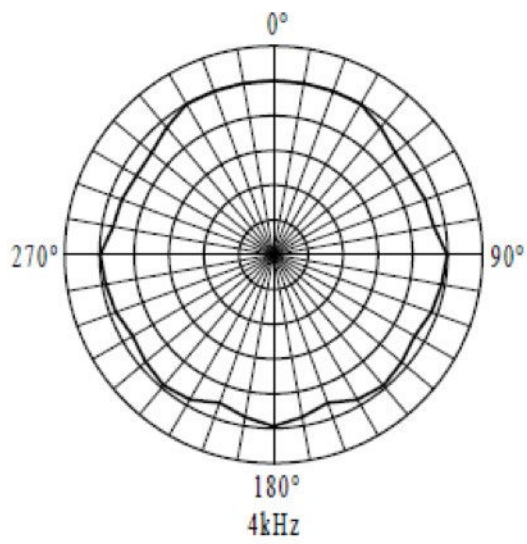
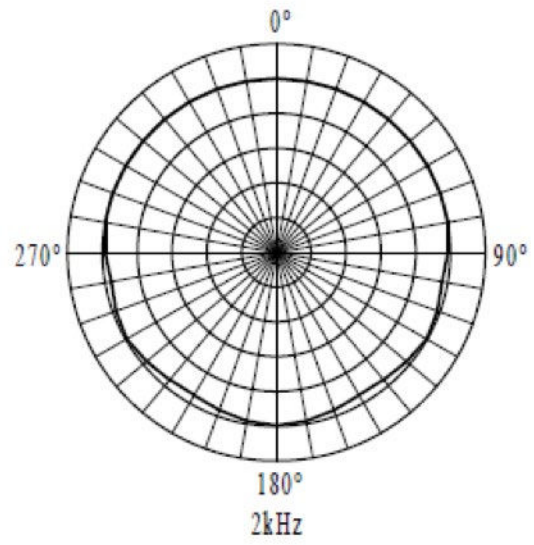
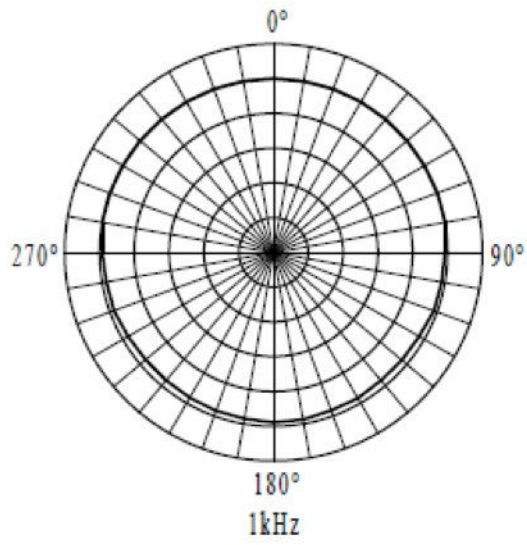

9 Options and accessories

The following table contains information about the model options and accessories available with this sound level meter.

| Cirrus Research part number | Descriptions |
|-----------------------------|---|
| CR:308 | Basic sound level meter with threshold |
| CR:310 | Basic sound level meter with measurement |
| PR:310 | Thermal printer (for use with CR:310 only) |
| CR:514 | Acoustic calibrator |
| CK:380 | Kit case (empty) |
| CK:381 | CR:308 kit including case, meter and calibrator |
| CK:382 | CR:310 kit including case, meter and calibrator |
| UA:30X | Spare windshield |
| CP:65 | Carrying pouch for sound level meter and calibrator |

10 Serial connection

DB9, RS232 communications rate at 9600 Baud.

1 bit start, 8 bits data, 1 bit stop, no parity

11 Declaration of Conformity

Manufacturer: Cirrus Research plc
Acoustic House
Bridlington Road
North Yorkshire
YO14 0PH
United Kingdom



Telephone: +44 (0)1723 891655

Equipment manufactured after June 2018.

Equipment description

CR:308 sound level meter
CR:310 sound level meter

According to:

EMC Directive 2014/30/EU
Low Voltage Directive 2014/35/EU
RoHS Directive 2011/65/EU

Meet the following standards:

EN 61000-6-3: 2007+A1: 2011
Electromagnetic compatibility (EMC). Generic standards. Emission standard for residential, commercial and light-industrial environments.

EN 61000-6-1: 2007
Electromagnetic compatibility (EMC). Generic standards. Immunity for residential, commercial and light-industrial environments.

Signed Friday, 27 August 2021

A handwritten signature in black ink, appearing to read 'M Williams'.

Martin Williams
Director



12 Product guarantee and extended warranty

1. Every new product is provided with a 12-month warranty. This covers everything we provide against failure, poor workmanship and accidental damage.

NB - European Union law states a product must be fit for purpose for 24 months after purchase. This two-year period covers failure and poor workmanship only.

2. If the product is calibrated by Cirrus Research or an authorised calibration and service centre, then the initial 12-month warranty is extended by a further 12 months, with the same conditions, for up to 15 years in total.

3. If a product has not been calibrated annually by Cirrus Research or an authorised calibration and service centre, then you may buy back into the warranty scheme for £100 plus the cost of calibration. This can only be done once during the life of the product.

4. If a microphone capsule fails under warranty and is physically damaged, we will replace it with a refurbished capsule.

5. If you don't wish to have a refurbished capsule, then you can trade in your damaged capsule for a new one, which will incur a fee of £150.

13 Cirrus Research contact details

In addition to independent sales channels in the UK, Germany and France, Cirrus Research also operates through approved distributors and agents in many countries worldwide. For details of your local representative, please contact Cirrus Research using the information below. Contact details for Cirrus Research authorised distributors and agents are also available from the website at the address shown below.

United Kingdom

Cirrus Research plc
Acoustic House
Bridlington Road
Hunmanby
North Yorkshire
United Kingdom
YO14 0PH

T: +44 (0)1723 891655

E: sales@cirrusresearch.com

W: www.cirrusresearch.com

Deutschland

Cirrus Research GmbH
Arabella Center
Lyoner Straße 44 – 48
60528 Frankfurt am Main
Deutschland

T: +49 (0)69 95932047

E: vertrieb@cirrusresearch.com

W: www.cirrusresearch.de

France

Cirrus Research France S.A.S.
679 avenue de la République
59800 Lille
France

T: +33 (0)633 976626

E: infos@cirrusresearch.fr

W: www.cirrusresearch.fr

Notes

Notes

Notes

Notes



www.cirrusresearch.com
sales@cirrusresearch.com